

INSTALLATION AND OPERATING INSTRUCTIONS

Industrial Duty Air Compressors

5 HP

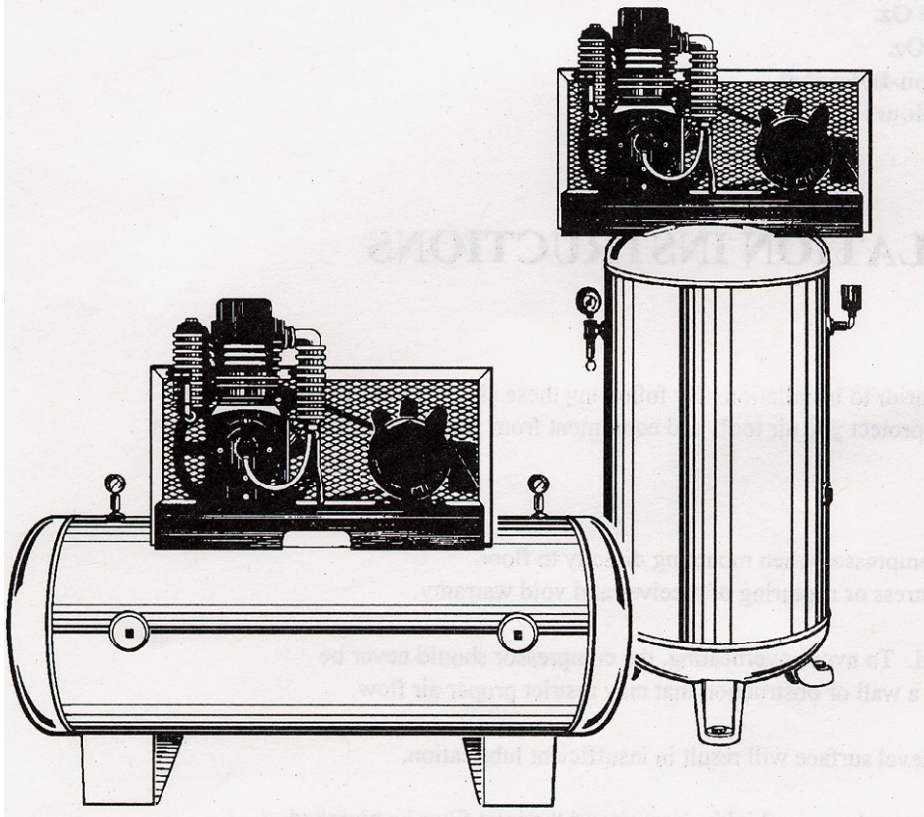

START UP PROCEDURES

Unpacking:

This product has been pre-tested at the factory and has gone through quality control inspection prior to shipping. Upon receiving this product, carefully inspect unit to assure that no damage or loss has occurred in shipping.

In the event that damage or loss has occurred, it should be noted on the freight carrier's bill of lading. The manufacturer of this product is in no way responsible for damage or losses. All claims must be filed through the carrier's claim department.

- 1.) Place compressor on level surface.
- 2.) Check oil level of compressor before each start up.
(The oil level should be maintained to the center of sight glass.)
- 3.) Make a thorough inspection of compressor to assure that there are no obstructions that might interfere with moving parts.
- 4.) **Rotation Warning:**
Your compressor is air cooled and equipped with a fan type flywheel. The compressor pump must rotate in the direction of the arrow on the flywheel.
(Improper rotation will cause over-heating and pump failure.)
- 5.) **Oil Capacity:** **10 HP = 65 Oz.**
 5 HP = 50 Oz.
Oil Type: **30 Wt. - Non-Detergent**
Oil Change Schedule: **200 - 300 Hours**

INSTALLATION INSTRUCTIONS

Important:

It is very important to read this section carefully prior to installation. By following these six (6) important tips you can increase your compressor life and efficiency and protect your air tools and equipment from water or particle contamination and over driving to high line pressure.

- 1.) **Vibration Pads:**
Must be used under the legs of the air compressor when mounting directly to floor.
Caution - Failure to do this may cause stress or rupturing of receiver and void warranty.
- 2.) **Location:**
Caution - Your compressor is air cooled. To avoid overheating, the compressor should never be operated any closer than 20" away from a wall or obstruction that may restrict proper air flow.
- 3.) **Compressor Level:**
Operation of this compressor on any unlevel surface will result in insufficient lubrication.
- 4.) **Air Intake:**
When operating compressor in a dirty atmosphere, we highly recommend the inlet filter be plumbed to fresh, clean air. This will improve your compressor's efficiency and life.
- 5.) **Metal Flex Hose:**
This is recommended between receiver outlet and shop piping and will prevent stress or breakage.
- 6.) **Water Filters:**
The most common cause of air tool failure are water and lack of lubrication. Filters are highly recommended and should be located downstream to assure adequate cooling of air.

**Industrial Duty
5 HP Electric Two-Stage**

